

## FULL AUTOMATIC L SEALER RLS PLUS SERIES

Packaging Solutions for High Capacity Productions



## RLS SERIES FEATURES

Packaging solutions for high capacity productions

Automated packaging without operator,  
Optimized packaging quality

With photo sensors and speed controllers, it is "easy-to-fit" with the production lines

Automatic product feeding with the in feed conveyor and photo sensors

Linking conveyor belt auto-extension function on the in feed belt to avoid jam

Professional type perforators to give high accuracy in hole punching

Additional film direction control reels bring up to 10% advantage in film consumption

Trim winder has been designed completely individual as a self operating system

Working with less amount of film in a complete accuracy

Wide and professional body design principal to make it "easy to reach" and "easy to automate"

Heat controlled seal bar with Teflon coating

Controlled left and right L bar heating with 1°C sensitivity

Automatic stop control with against package mis-feed

PLC controlled, LCD touch screen operator panel

Native languages are applied

Speed controller for product conveying adjustment

Automatic package length detection

Sensor controlled trim breakage control with warning message

Warning LCD messages for potential emergency cases

"Speed Navigation Control" shows the actual throughput and estimated packs per/time values

Saved package parameters can be called from memory

Package counter

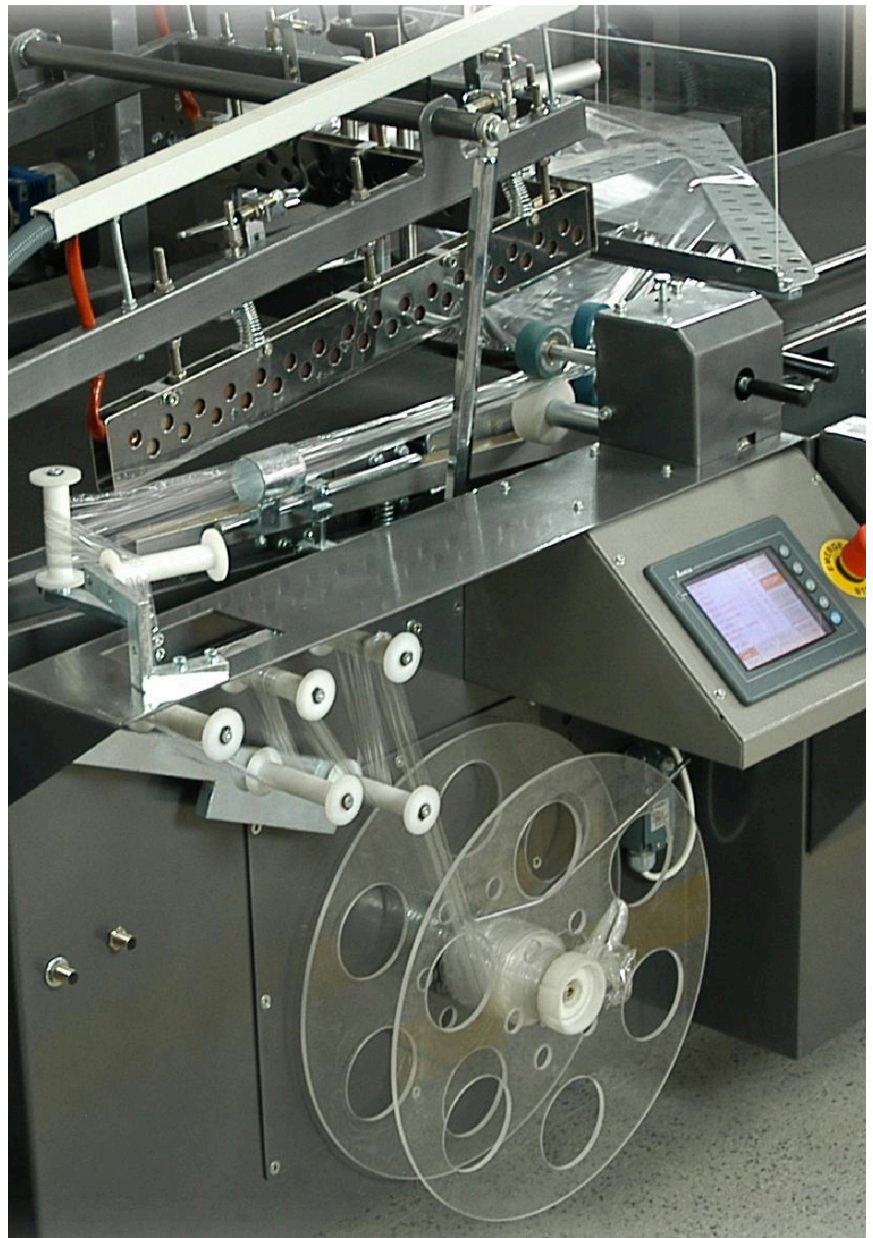

<b>RLS SERIES SPECIFICATIONS</b> PRODUCT CODE	<b>CLS 5844</b> in 2014	<b>RLS 5844</b> Y12 009 0012
<b>SEALING AREA</b> (MM/INCHES)	in 2014	580 x 440 MM 22"x17"x9"
<b>MAXIMUM FILM WIDTH</b> (MM/INCHES)	in 2014	550 MM 21"
<b>MACHINE WEIGHT - NET</b> (KG/LBS)	in 2014	560 KG 1234 lbs
<b>MACHINE WEIGHT - CRATED</b> (KG/LBS)	in 2014	620 KG 1366 lbs
<b>POWER SUPPLY</b>	in 2014	400 V 12 Amps 3 Ph
<b>CONSUMPTION</b> (MAX/AVERAGE)	in 2014	3,7 kW / 1,9 kW
<b>AIR SUPPLY</b> (PER CYCLE)	in 2014	6 Bar 55dm <sup>3</sup> 304in <sup>3</sup>
<b>MAXIMUM JAW HEIGHT</b> (MM/INCHES)	in 2014	170 MM 6,5"
<b>PACKED DIMENSIONS LxWxH</b> (MM/INCHES)	in 2014	2140 x 1674 x 1640 84"x66"x64"
<b>MAXIMUM PACKAGING CAPACITY</b>	in 2014	25 - 30 PACKS/MIN
<b>COLOR</b>	in 2014	METALLIC DARK GRAY

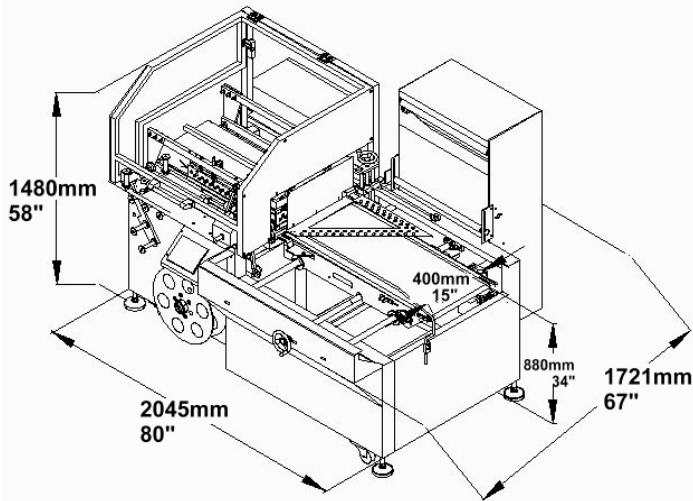

**ISO 9001 QUALITY STANDARD WITH THE RELEVANT NORM'S CONFIRMATIONS**

CE marking

Manufacturer's guarantee for spare part stock and after sales support.

One year warranty on non-wearable parts

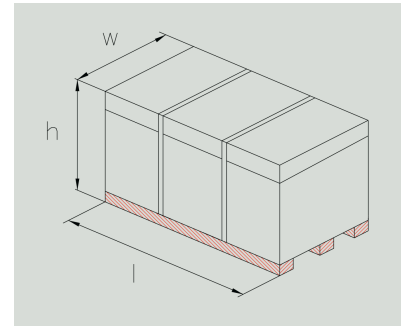

**PARK ENDÜSTRİYEL ÜRÜNLER LTD.**  
Atalar Caddesi. Gamze Sokak No: 13 / A  
Kartal / İstanbul - TÜRKİYE

**POSTA KODU:** 34862  
T +90 216 353 5466  
F +90 216 353 6049



ISO 9001:2000 REGISTERED COMPANY